

Axiom Series Refrigerant Gas Detector

For detection and measurement of refrigerant gases



UL60335-2-40
CERTIFIED*

PST gas detectors are designed with patented nondispersive infrared technology for the detection and measurement of the presence of refrigerant gases. To meet the growing need for lower global warming potential (GWP) refrigerant gases, Dynament offers detectors for both flammable (A3, A2, A2L) and non-flammable (A1) refrigerants.

Dynament NDIR detectors have a twenty-year history of meeting and exceeding gas detection needs in the most challenging of environmental applications. The Axiom series platform provides a linearized, high-resolution measurement of refrigerant gases over the lower explosive limit range.

Key Features	Axiom Diagnostic Tool (ADT)												
<ul style="list-style-type: none"> Measures refrigerant gases in the LFL range with a resolution of 0.05% (500ppm) Fail-safe operation Immune to poisoning 15 year lifetime with no calibration requirements Digital or Analog output options Open Collector to drive relay at present alarm level Detector End-of-Life (EOL) fault indication 5-24V voltage input range USB-C connector [rated IP68] allows for off-the shelf cabling options Onboard heater and software algorithm to minimize the impact of condensation Plug-and-Play functionality with all the necessary optics, electronics, and firmware to provide a linearized, temperature-compensated output. 	<div style="text-align: center;"> <p>Gas Reading</p> <p>0.54%LFL</p> <p>Connection Status</p> <p>Connected: Ready</p> </div> <div style="display: flex; justify-content: space-around; margin-top: 10px;"> <div>View Status Flags</div> <div>Config Unit</div> </div> <table border="1" style="width: 100%; margin-top: 10px;"> <tr> <td>Batch Number</td> <td>B9872N20</td> </tr> <tr> <td>Serial Number</td> <td>00347</td> </tr> <tr> <td>Firmware Revision</td> <td>09.02.12A (09 April 2024)</td> </tr> <tr> <td>Sensor Type</td> <td>Uni</td> </tr> <tr> <td>Alarm Level</td> <td>5.0% LFL</td> </tr> <tr> <td>MODBUS Address</td> <td>1</td> </tr> </table> <p>Axiom Diagnostic Tool (ADT) requires USB-C to USB PC cable connection. Axiom diagnostic information is available through a PC application, providing real time gas reading, access to configuration settings (baud rate, Modbus address) and detailed fault information to assist with service and maintenance.</p>	Batch Number	B9872N20	Serial Number	00347	Firmware Revision	09.02.12A (09 April 2024)	Sensor Type	Uni	Alarm Level	5.0% LFL	MODBUS Address	1
Batch Number	B9872N20												
Serial Number	00347												
Firmware Revision	09.02.12A (09 April 2024)												
Sensor Type	Uni												
Alarm Level	5.0% LFL												
MODBUS Address	1												

*Applies to R454B only

Technical Specifications

@ 20 °C (68 °F) ambient temperature

Operating Voltage		
5 - 24VDC		
Operating Power	Alarm Level	
0.5W average	Based on refrigerant (5% LFL for R454B)	
Vibration & EMC		
Certified UL60335-2-40 Annex LL		
IP Rating		
IP54		
Accuracy @ alarm point	Pressure	
± 3%	80 to 110kPa	
Response Time	Warm Up Time	
<15s (to alarm level)	45s	
Operating temperature range		
-40 °C to +75 °C (-40 °F to 167 °F)		
Humidity range		
0 to 100% RH non-condensing		
Digital Outputs		
RS485 Modbus	RS232 UART	USB 2.0
Analog Outputs		
4-20mA	0.2-4.0V	Open Collector
Lifetime	Weight	
15 years	50 grams	

Order Code

Generate your specific part number using the convention shown below. Use only those letters and Numbers that correspond to the sensor and output options you require – omit those you do not.

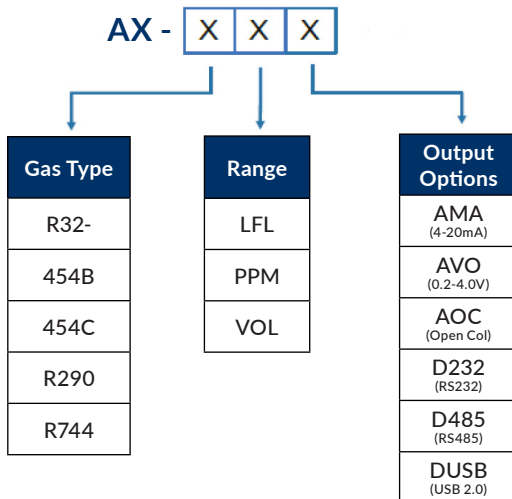

Product Dimensions



Refrigerant Gases and Ranges

Gas Type	Range	Resolution	Safety Classification
R32	0-14.4% volume	0.05% vol. 500ppm	A2L
R454B	0-11.5% volume	0.05% vol. 500ppm	A2L
R454C	0-7.7% volume	0.05% vol. 500ppm	A2L
R290 (Propane)	0-2.1% volume	0.01% vol. 100ppm	A3
R1270 (Propylene)	0-2.7% volume	0.01% vol. 100ppm	A3
R744 (CO ₂)	0-500ppm	10ppm	A1
R744 (CO ₂)	0-5000ppm	10ppm	A1
R744 (CO ₂)	0-5% volume	0.01% vol. 100ppm	A1

Additional ranges and gases available upon request.

Safety Classifications Explanation*

Toxicity	Flammability	LFL	Flame Propagation
A: Lower Toxicity	1: Non flammable	N/A	No flame propagation
	2: Lower flammability	>3.5% vol.	Exhibit flame propagation
B: Higher Toxicity	2L: Lower flammability	>3.5% vol.	Exhibit flame propagation**
	3: Higher flammability	≤3.5% vol.	Exhibit flame propagation

* Flame propagation testing conducted at 60 C and 101.3kpa
 ** Exhibit flame propagation & maximum burning velocity of ≤ 10 cm/s when tested at 23 C and 101.3 kPa

Output wiring schematic (four conductor cable)

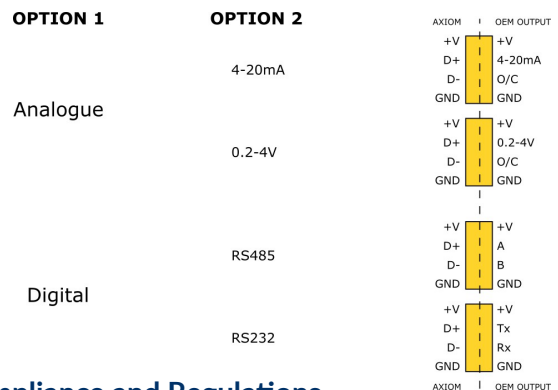

Compliance and Regulations



UL 60335-20-40 Edition 4 Annex LL | CSA 22.2 60335-2-40 Ed 4

Dynamet is part of Process Sensing Technologies (PST). As customer applications are outside of PST control, the information provided is given without legal responsibility. Customers should test under their own conditions to ensure the equipment is suitable for the intended application(s). We adopt a continuous development program which sometimes necessitates specification changes without notice. For technical assistance or enquiries about other options, please contact us here: sensors@processsensing.com

HERMITAGE LANE INDUSTRIAL ESTATE, KINGS MILL WAY, MANSFIELD, NOTTINGHAMSHIRE, NG18 5ER | TEL: 44 (0) 1623 663636